

TECHNICAL DATA:

Easily accessible device,  
according to standard EN 1176-1:2017

- Device dimensions: 0,45 x 0,80m
- Device height: 0,74m
- Minimum space: 3,45 x 3,80m
- Falling area: 11,17m<sup>2</sup>
- Critical fall height: 0,57m
- Foundations depth: -0,60m

Top view with impact area

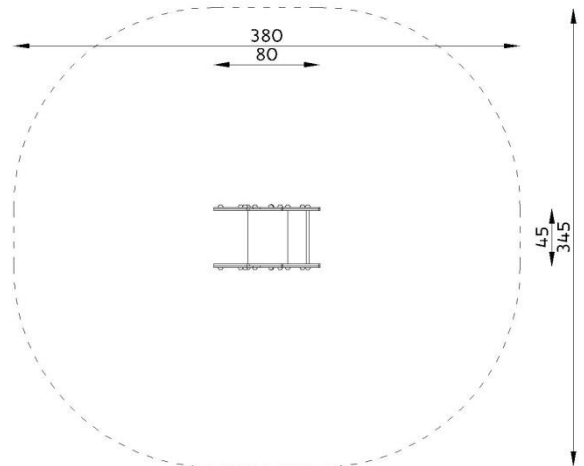

The device according to EN 1176-1:2017  
Playground equipment and surfacing – Part 1:  
General safety requirements and test methods

- Safety surfaces:
- turf/topsoil, sand, gravel, bark, synthetic surface
  - minimal thickness for loose particulate materials 200+100mm
  - synthetic surface according to critical fall height

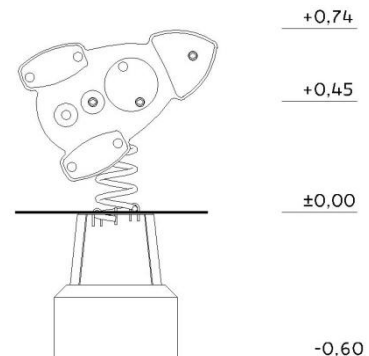

## MATERIALS:

|                       |                                  |
|-----------------------|----------------------------------|
| Flat elements:        | HDPE sheets                      |
| Foundation base:      | openwork steel construction      |
| Handles, legs suport: | stainless steel                  |
| Spring:               | galvanized steel, powder painted |
| Steel elements:       | galvanized steel, powder painted |
| Caps:                 | plastic                          |
| Foundations:          | concrete min. C12/15 standard    |



SATERNUS DISTRIBUTION Sp. z o.o. sp.k.  
ul. Nowa 32  
41-500 Chorzów, Poland

Certificate beholder:  
Producer:  
Distributor:

GRUPA SATERNUS Sp. z o.o. S. K. A. reserves all rights to protect copyright under the Act of February 4, 1994 on Copyright and Related Rights (Journal of Laws No. 28, pc 83), and in particular Art. 78 and 79 of this Law.

GRUPA SATERNUS Sp. z o.o. S. K. A.  
Saternus Production Sp. z o.o. sp. k.  
Saternus Distribution Sp. z o.o. sp. k.