



1117EPZN



Description

1 square platform, 1 triangular platform, 1 slide 104, 3 safety HDPE boards with decorative cuts, 1 entrance, 1 climbing bar, 5 metal fittings to be installed in the ground

Model type	Modulair
Serial number	1117EPZN
Equipment name	Platform 2 1117

Join the action!

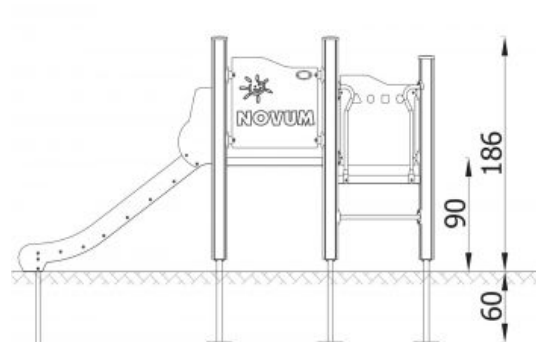
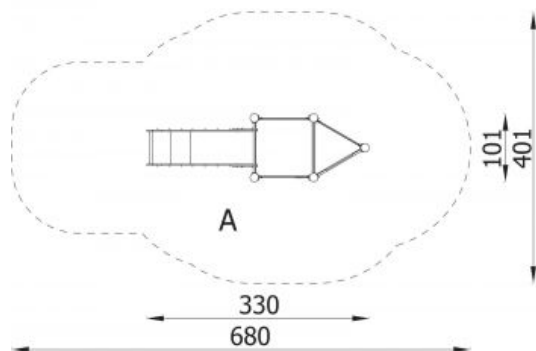

Product line	Action Orbis Wood Modulair
Age range	3 - 12
Unit measurements	100cm x 330cm x 200cm
Required surface area	400cm x 730cm
Impact area	23m ²
Free height of fall	105cm
Material	Bearing posts have a diameter of 12 cm and are made of glue-laminated, round, wood, fixed 10 cm above the ground level with metal anchors. Antislip platforms. Roofs, security elements and panels are made of HDPE (high durable polyethylene) boards with pattern cuttings. Sliding surface is made of acid-proof, stainless steel sheet. Ropes made of polypropylene with a steel core, thickness 16-18 mm, vandalism and UV resistant. All fittings and connectors are weather and UV resistant. Wood elements are oiled or covered with a colour glaze. Steel elements are protected against corrosion by zinc primer and powder paint coating.
Heaviest part	70kg
Largest part	80cm - 300cm
Spare parts	Available
Installation time without groundwork	5 hour(s) / 3 person(s)
Special tools	Included
Anchoring	Poles are fixed in the ground at a depth of 60 cm on steel anchors. Concrete according to the assembly instructions.
Remarks	This equipment is also available with hot dip galvanized posts. Prices on request.