

Cradle Swing – Stainless Steel

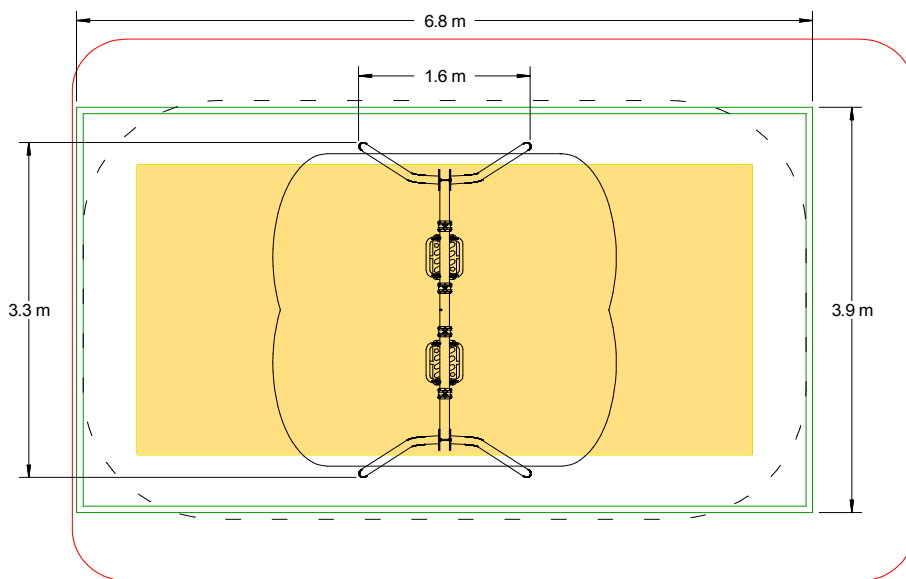
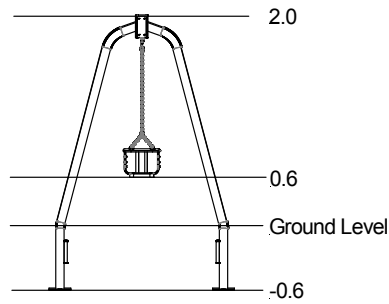

Circulation Area

Technical Information

Equipment Dimensions

Length / Width / Height 3.3m x 1.6m x 2.0m

Surfacing and Area Required

Minimum Space Required L/W/H 3.9m x 6.8m x 2.5m

Max Gradient Of Ground 1 in 50

Free Height Of Fall 1.3m

Impact Area 15.87m²

Loosefill At 250mm 6.33m³

Bark / Cushionfall / Sand

Grasslok Tiles 23m²

Installation Information

Overall Weight 97kg

Heaviest Part 20kg

Largest Part 2.5m x 0.2m x 0.1m

Longest Part 2.5m

Concrete Required 0.25m³

KITEMARKED TO BS EN 1176