

Adventure Trail – Interactive Panel

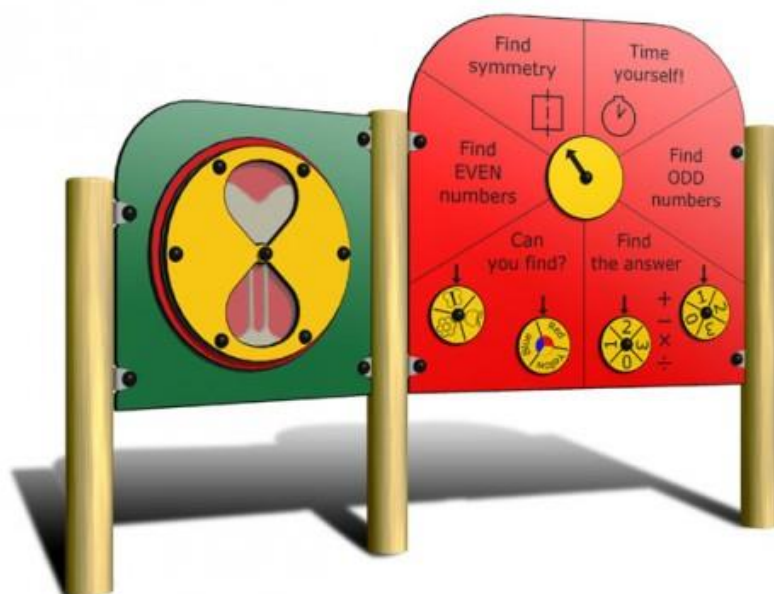

Code – ITR(2)

Age

3-14 years

Materials

Compact Grade

Laminate (CGL)

Laminated Timber

Stainless Steel

Various Coloured

Plastics

Product Description

Rotating Sand Timer and Engraved Instruction Panel with rotating pointers manufactured from CGL with laminated timber legs.

Technical Information

Equipment Dimensions

Length / Width / Height **2.0m x 0.15m x 1.14m**

Surfacing and Area Required

Recommended Minimum Space L/W/H **4.5m x 2.7m x 2.25m**

Max Gradient of Ground **1 in 20**

Free Height of Fall **N/A**

Impact Area **N/A**

Synthetic Area (i.e. EPDM / Wetpour / Synthetic Grass etc.) **N/A**

Loosefill at 150mm (i.e. Bark / Cushionfall / Sand) **N/A**

1m x 1m Grassmats **N/A**

Installation Information

SGF

SF (if different)

Installation Time **2 Person(s) 4 Hour(s)**

Overall Weight **73kg**

Heaviest Part **18kg**

Largest Part **0.9m x 0.15m x 0.15m**

Longest Part **0.9m**

Concrete Required **0.1m³**

Certified to EN 1176

[Click here for more information & downloads](#)



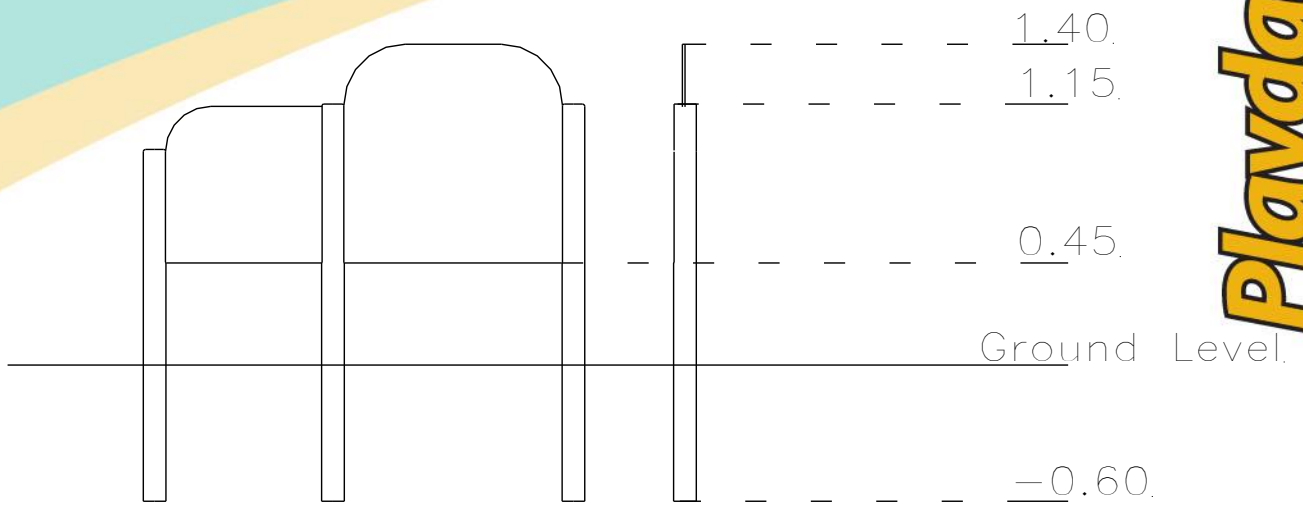

-  Impact Area
-  Free Space
-  Synthetic Area

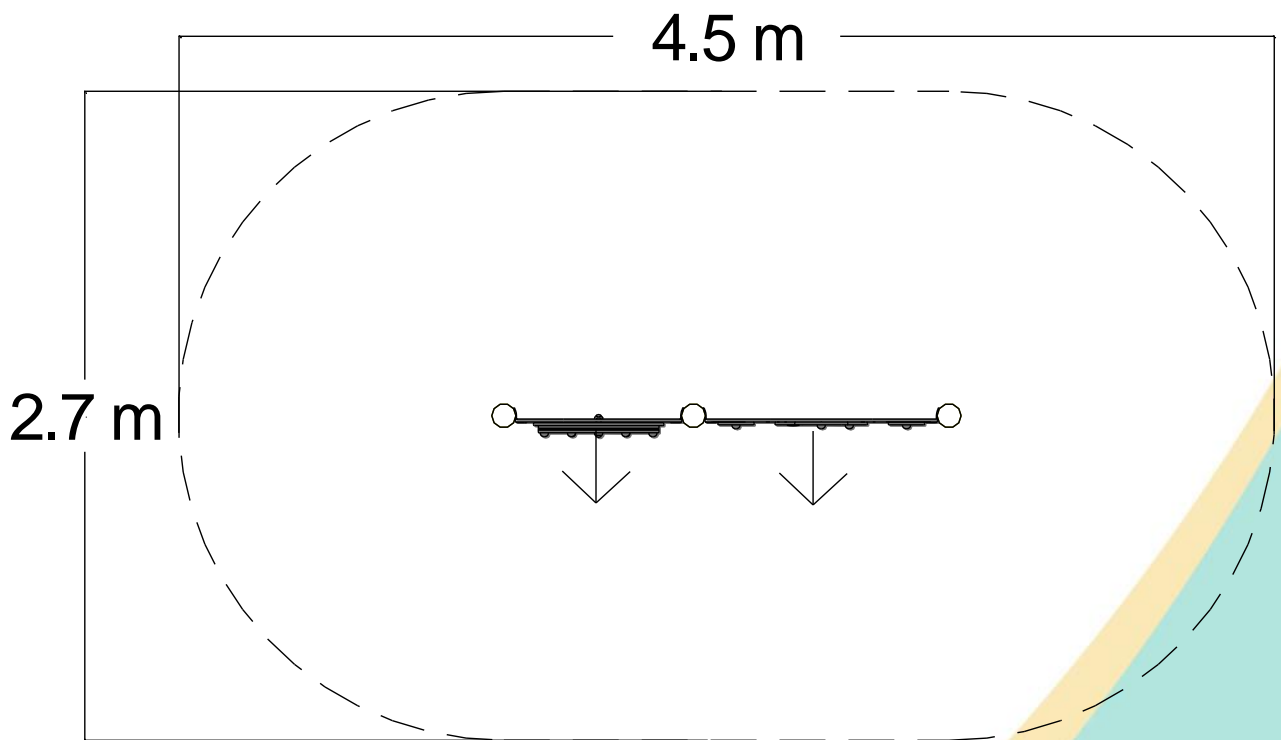

[Click here for more information & downloads](#) 