

Growth Measure

-  Loosefill Area
-  Suggested Hardstanding
-  Free Space
-  Unit Spacing Boundary

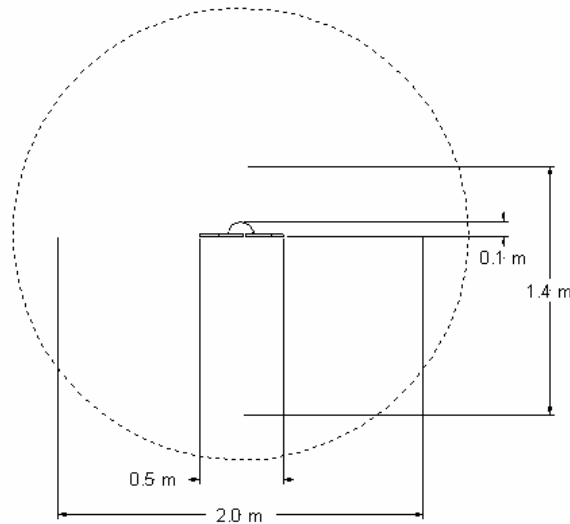
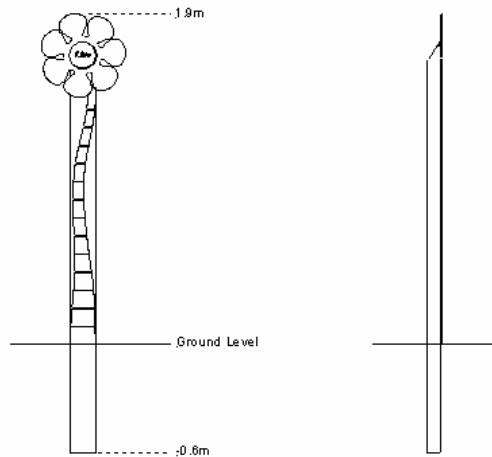

Technical Information

Equipment Dimensions

Length / Width / Height **0.1m x 0.5m x 1.9m**

Surfacing and Area Required

Minimum Space Required L/W/H **2.0m x 1.4m x 3.1m**

Max Gradient Of Ground **1:30**

Free Height Of Fall **n/a**

Suggested Hardstanding **n/a**

Loosefill at 150mm **n/a**

Bark / Cushionfall / Sand **n/a**

1m x 1m Rubber Tiles **n/a**

Installation Information

Overall Weight **26kg**

Heaviest Part **14kg**

Largest Part **2.3x0.14m**

Longest Part **2.3m**

Concrete Required **0.05m³**